



PROJECT CATALOGUE 2026

PROTECTING BYSTANDERS AROUND THE WORKSPOT



OUR MISSION.

We create safe working environments worldwide with reliable solutions for welding safety. Through craftsmanship, personal commitment and genuine collaboration, we ensure it works for every customer, in every situation.

OUR VALUES. OUR PROMISE.

QUALITY

We always strive for the best solution. No compromises, only products and services we can fully stand behind. Quality is not just a promise, it is our standard, with the customer always at the centre.

CONNECTION

Strong relationships form the core of Cepro. We invest in personal contact with customers, dealers, suppliers and colleagues. Together, we build sustainable cooperation where everyone feels valued.

TRUST

A deal is a deal. Customers and partners can rely on us. We do what we say and say what we do, and have done so for years. This makes Cepro a reliable partner in every collaboration.

COMMITMENT

Every request, large or small, receives our full attention. We listen, think along actively and take that extra step. This makes us valued not only as a supplier, but as a partner you can rely on.

PRIDE

We are proud of who we are and what we do. We care for each other and for our work. This dedication is reflected in solutions that not only meet expectations but often exceed them.

GROWTH

At Cepro, there is room for development, for people and for partnerships. By combining experience with new ideas, we continue to improve. We grow together, with respect for where we come from and ambition for where we are heading.

OUR VISION.

Cepro envisions a world where safety, trust and quality are the standard at every workplace. We believe that long-term relationships, human connection and smart innovations go hand in hand. As a trusted partner, Cepro aims to be present in every country where recognised safety standards apply. We strive for global impact, with the heart of a family business.

FROM STANDARD PRODUCTS TO COMPLETE SOLUTIONS

Beyond products: delivering solutions

At Cepro, we know that every workplace is different. While our product catalogue highlights our wide range of standard products, our real strength lies in creating complete solutions. Together with our customers, we develop safe and practical setups that meet specific requirements and comply with all relevant standards.

Turning challenges into results

Each project brings unique demands. Whether it involves protection against welding light, sparks or noise, or creating entire welding cabins and production zones, Cepro combines expertise with proven products to deliver reliable, effective outcomes.

Certified safety, guaranteed quality

Safety is central to everything we do. All Cepro solutions are made from certified materials and tested according to strict European standards, ensuring long-term reliability and compliance.

A trusted partner in workplace safety

With Cepro, you gain more than a supplier, you gain a partner. From first assessment to final delivery, we work closely with you to design and implement solutions that protect people, safeguard production and support efficiency.

Discover our projects

This catalogue highlights a selection of realised projects worldwide, showing how functionality, safety and design come together in practice. With Cepro, you can be confident of solutions that meet the highest demands, today and tomorrow.





STINIS CHOOSES A SLEEK, QUIET AND SAFE WORKSHOP

Stinis, a family-owned company with nearly 200 years of experience and known worldwide for its container spreaders, opted for a modern workshop design. We delivered a solution that combines calm, safety, and a professional look matching Stinis' craftsmanship.

Why it works:

- ▶ Cepro Sonic sound-absorbing walls significantly reduce noise levels, creating a calm and pleasant workspace.
- ▶ The design integrates seamlessly with the factory's aesthetics, combining functionality and visual comfort.
- ▶ Employees benefit from ergonomic workstations that ensure safety and well-being.

The situation:

The old workshop was functional but cluttered, with poor soundproofing that did not reflect Stinis' premium quality.

Our solution:

Fixed welding strips and soundproof walls created logical, professional workspaces that improve comfort and leave a strong impression on clients.

The result:

A future-ready workshop with calm, safe conditions for employees and a professional facility for clients and visitors. This project shows how tailored solutions can turn a workshop into both a workplace and a company showcase.

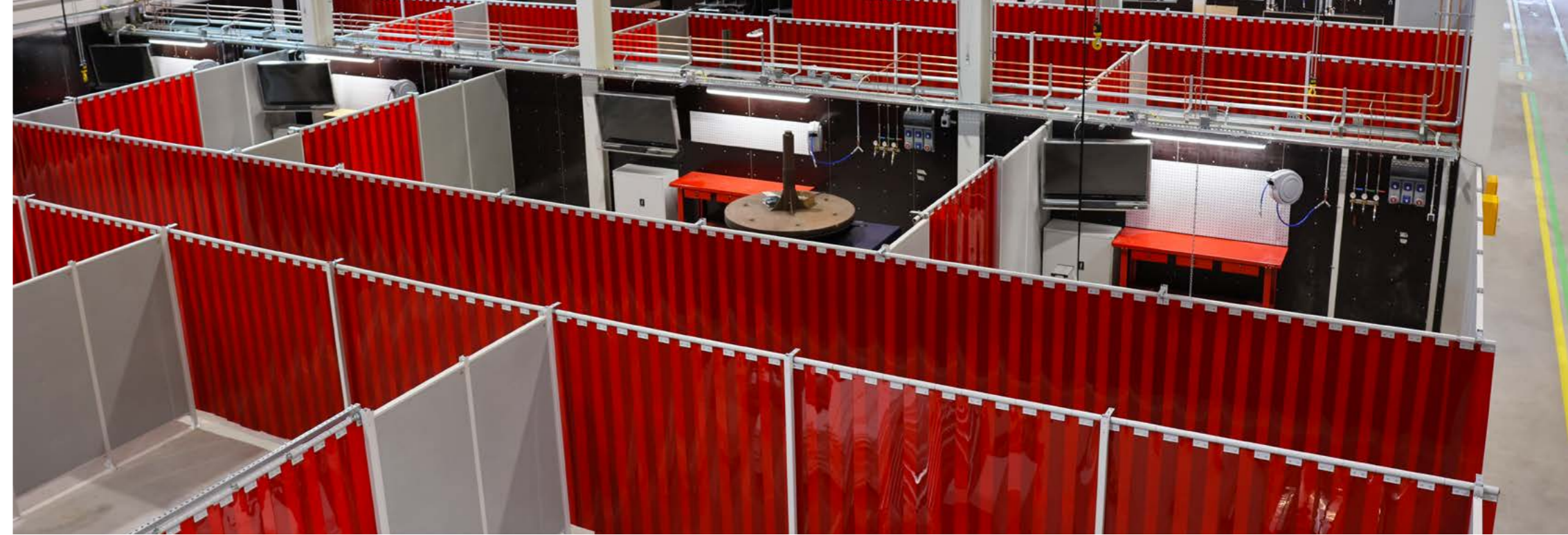



A FRESH START: SAFE AND EFFICIENT WELDING WORKSHOP AT EDUGO

To ensure students can learn safely, a well-equipped technical training environment is essential. For Edugo, a school specializing in sports and technology, we delivered a fully redesigned welding workshop and a custom-built grinding booth.

Why it works:

- ▶ The welding workshop was fully redesigned with new welding booths.
- ▶ Cepro built a tailor-made grinding booth with six workstations, allowing multiple grinders to operate safely and efficiently without compromising ventilation or space.
- ▶ Through close cooperation with the school and partners, the entire project, from design to installation, was completed within four months.

The situation:

Edugo's old workshop was outdated, with poor ventilation and safety standards.

Our solution:

Cepro installed new welding booths, with durable materials and a layout designed for modern technical education, including a six-station grinding booth with strong ventilation.

The result:

A safe, motivating, and future-proof workshop where students learn effectively and teachers benefit from better safety and visibility.





NEW TRAINING FACILITY FOR GILDE TECHNICAL COLLEGE

A modern learning environment requires safe, flexible, and future-proof workplaces. For Gilde Technical College, we contributed to the creation of an innovative training workshop where students can explore welding in a professional setting that reflects real industry requirements.

Why it works:

- ▶ Cepro welding booths protect against both welding light and noise, ensuring a safe and comfortable learning environment.
- ▶ The modular design makes the booths flexible and adaptable to future developments such as automated welding.
- ▶ Durable, wear-resistant materials are low-maintenance and suitable for intensive use in education.

The situation:

When building its new technical school, Gilde sought a training facility that truly reflects real-world practice. Employers stressed the importance of a realistic environment that mirrors industry standards.

Our solution:

We designed and delivered multiple welding booths with soundproofing and modular flexibility. Through collaboration with electricians and welding specialists, the project was completed smoothly and on schedule.

The result:

A modern training space that motivates students and reflects real industry practice. Teachers and students benefit from a safe, realistic environment designed for long-term use and easy integration of future technologies.





SAFE AND ORGANIZED WELDING FOR AGRICULTURAL MACHINERY

When designing a modern welding facility, safety, structure, and efficiency are key. We delivered a well-thought-out workplace design for an international manufacturer of agricultural machinery, ensuring clarity and safety on the work floor.

Why it works:

- ▶ Cepro welding strips provide shielding that complies with international standards, protecting staff from harmful UV and IR radiation.
- ▶ Clearly separated workstations create calm and structure, helping welders to focus.
- ▶ Certified, robust materials give the workplace a durable and professional appearance, perfectly suited to a high-end production environment.

The situation:

An international manufacturer of agricultural machinery sought an efficient and safe setup for multiple welding stations within a newly designed production facility.

Our solution:

We designed a series of enclosed welding stations with certified welding strips and sound-absorbing walls. This combination provides a safe environment with minimal noise and a professional, organized appearance.

The result:

A well-structured, safe, and durable workplace that meets the highest safety standards, combining functionality with a professional image.





SAFE AND QUIET WORK: NEW WELDING LINE FOR VAN HOOFF GROUP

At Van Hoof Group in Asten, we delivered a complete line of welding booths that perfectly combine safety, comfort, and design. Thanks to sound-absorbing Sonic walls, the workspace is not only quieter and more pleasant but also blends seamlessly with the existing factory style.

Why it works:

- ▶ Cepro Sonic sound-absorbing walls significantly reduce noise levels, cultivating a peaceful and welcoming work setting
- ▶ The aesthetically integrated design blends seamlessly with the existing factory atmosphere, combining functionality with visual comfort.
- ▶ Employees benefit from an ergonomically designed workspace that ensures safety while promoting well-being.

The situation:

An existing production facility needed new work areas where welders could work without noise disturbances and without disrupting the factory's aesthetic.

Our solution:

A complete line of noise-reducing welding booths with Cepro Sonic walls in a custom color scheme, designed and installed in collaboration with a Cepro dealer.

The result:

Modern workstations where welders can focus without the distraction of noise or clutter. The use of high-quality sound-absorbing materials makes the environment significantly calmer and more comfortable, contributing both to well-being and job satisfaction. This project demonstrates how safety and functionality can go hand in hand with comfort and design.



FROM PROJECTS TO PRODUCTS

The foundation of every project

Behind every Cepro project lies a carefully selected set of products and components. These elements may seem small, but together they form the basis of safe, efficient and durable welding environments. From brackets, rails and hooks to panels, strips and connectors, each part plays a key role in creating reliable and compliant solutions.

From parts to complete solutions

What you have seen in the project examples are finished workplaces: quiet workshops, professional training facilities, safe welding cabins. On the following pages, we highlight the individual components that make these projects possible. By showing the parts separately, we give you insight into the many possibilities and combinations within the Cepro range.

Guidance from the specialist

Every workplace is different, which is why Cepro does more than supply products. Our specialists advise, design and help you select the right components for your specific situation. Whether it's a single welding curtain, a modular booth or a complete training facility, we combine certified materials with expertise to create solutions that truly work.

From components to confidence

With certified quality, proven safety and expert support, Cepro components become more than just parts, they are the building blocks of safer, smarter and more professional workplaces.

Do you have questions or a project in mind?

Contact Cepro, our team is ready to help you turn these components into a complete, practical and future-ready solution.

COMPONENTS THAT BUILD SAFE AND PRACTICAL SOLUTIONS

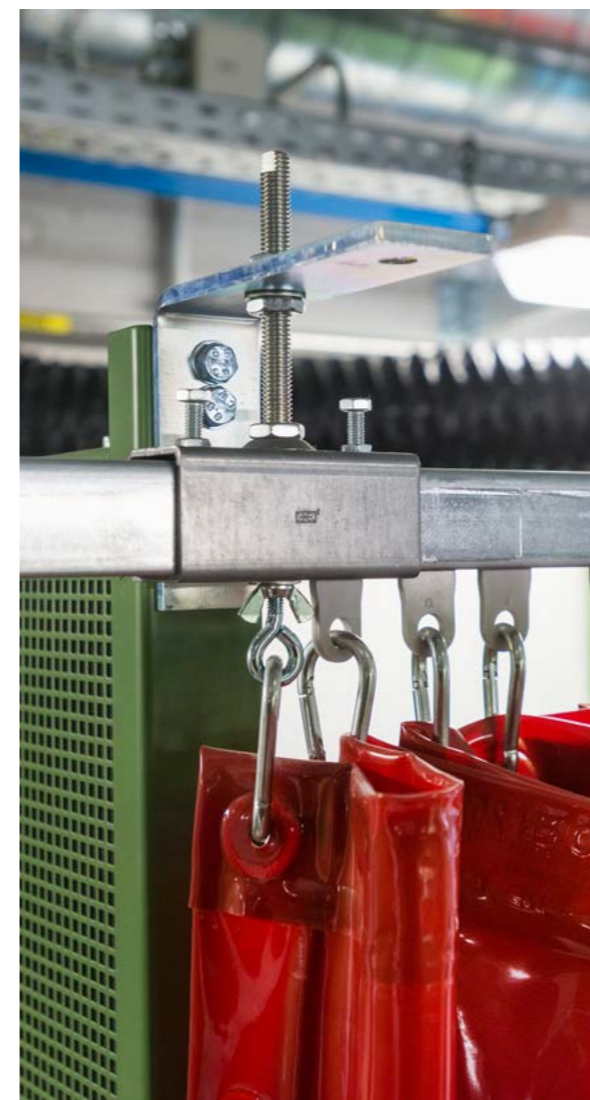

SONIC CLASSIC

Welding and grinding are among the main noise sources in industrial environments. Prolonged exposure not only risks hearing damage and illness-related absence, but also reduces focus, quality and productivity.

The Cepro Sonic wall system provides proven noise reduction through its compact design with built-in soundproof elements. Modular and flexible, it can be quickly assembled, extended, relocated or reconfigured, delivering both safety and cost efficiency.

All Cepro Sonic products are extensively tested by independent institutes and meet the highest standards, including flame-retardant properties. Available as wall elements, accessories, supports or complete booths, every system can be tailored to size, design and colour.

Cepro specialists are ready to advise you on creating safer, more efficient workplaces. Contact us to discover how Sonic can make the difference in your environment.

sound-absorbing - modular - easy & quick mounting - easy to expand

Sonic wall element - 1.012 mm wide

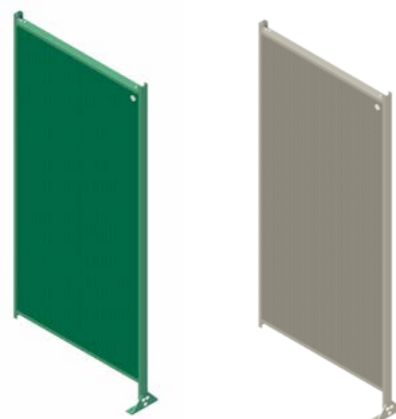

45.00.00.2010

45.00.10.2010

Sonic wall element - 1.012 mm wide, Impact window

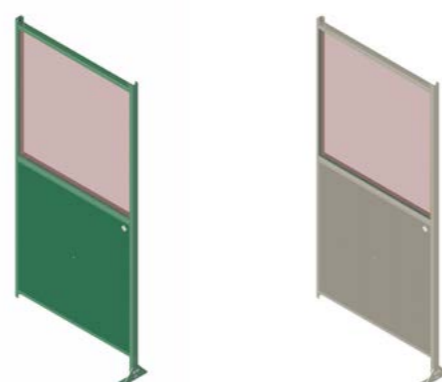

45.00.03.2010

45.00.13.2010

Sonic wall element - 512 mm wide

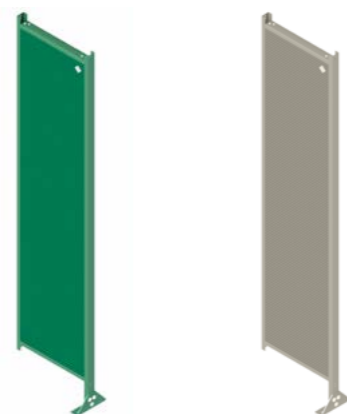

45.00.00.2005

45.00.10.2005

Sonic connecting pole - intersection & coupling



45.20.01

45.20.11

SONIC CLASSIC

sound-absorbing - modular - easy & quick mounting - easy to expand

Sonic adjustable foot

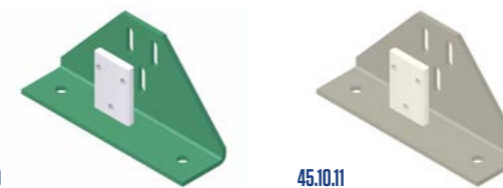

45.10.00

45.10.11

Sonic console for fume extractor

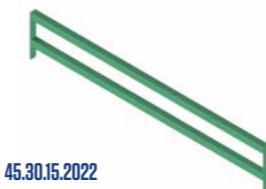

45.30.15.2022

Sonic extension for adjustable foot



45.35.20

Sonic support for rail or tube



80.10.01

Sonic grinding booth 200 x 200 cm

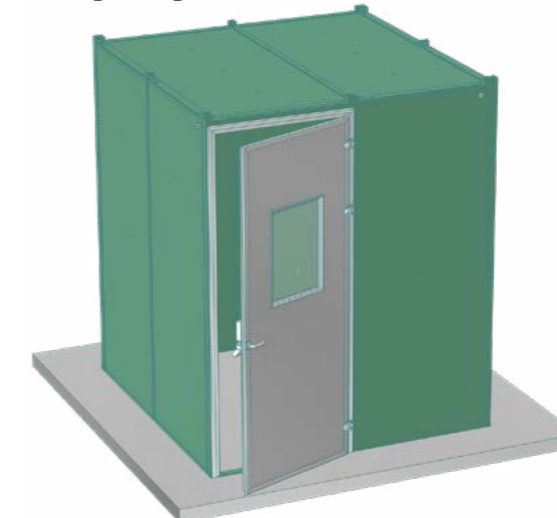

Sonic grinding booth 300 x 200 cm

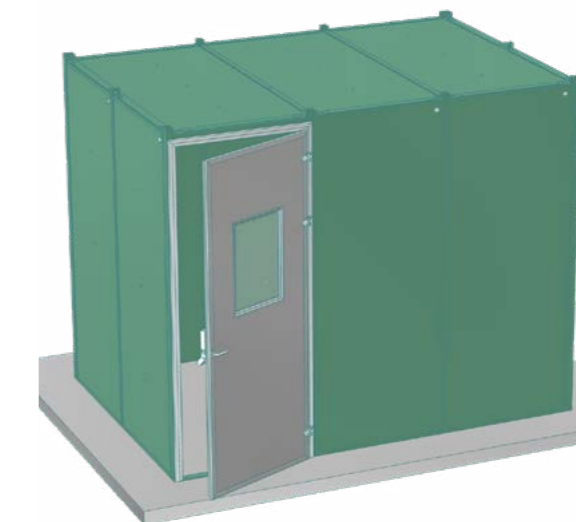

Sonic sound insulating screen



46.30.00.2221

Sonic absorbing curtain



92.15.01

(fitted in Cepro Robusto screen)

RAIL SYSTEM

The Cepro rail system is specially designed for sliding workshop partitions. Thanks to carefully matched components, such as rails, supports, buffers and runners, you can quickly and easily create a structure tailored to your exact situation.

The system is easy to install, simple to expand, and offers maximum flexibility for creating professional partitions.

With the Cepro rail system, you can effortlessly integrate various Cepro products such as welding curtains, welding strips and other shielding solutions. Creating a durable, user-friendly set-up that contributes to a safe and efficient workplace.

Our dedicated product catalogue goes into more detail on all available standard items like welding curtains, strips, blankets, screens etc.

Would you like to receive our product catalogue?
 Contact our sales team, we'll be happy to advise you on the best solution for your needs.

Rail 30 x 35 mm



86.10.00

Railbend 90°, radius 500 mm



86.10.01

Rail support



86.10.02

Rail support - connector



86.10.03

modular - flexible - versatile

Rail ceiling support - single



86.10.20

Rail ceiling support - double



86.10.21

Rail ceiling support - triple



86.10.22

Rail wall support - connector



86.10.15

RAIL SYSTEM

Wall support



86.10.04

Ceiling support



86.10.05

Wall support (double)



86.10.01

Wall support heavy duty



86.10.02

Runner plastic



86.10.10

Runner metal



86.10.11

Runner metal - four wheel



86.10.13

Runner metal - four wheel, with M10 bolt



86.10.17

modular - flexible - versatile

Snap hook



10.48.30

Slide hook



10.48.60

Endpiece for rail



86.10.07

Rail stop with buffer

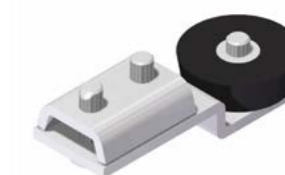

86.10.08

TUBE SYSTEM

The Cepro tube system is the ideal solution for fixed workshop partitions that do not need to be moved. With a wide range of components, including tubes, connectors, base plates and fastening materials, you can quickly and easily create a stable structure that fits your workplace perfectly.

The system combines strength with design flexibility, enabling you to create custom solutions with ease. Whether it is for mounting Cepro welding curtains, welding strips or other shielding solutions, the tube system allows you to create durable, professional partitions that contribute to safety and efficiency in the workplace.

Our dedicated product catalogue goes into more detail on all available standard items like welding curtains, strips, blankets, screens etc.

Would you like to receive our product catalogue?

Contact our sales team, we'll be happy to advise you on the best solution for your needs.

Tube 33,7 mm - Ø 2.9mm



86.40.00

Tube connector



86.40.30

Ceiling support



86.40.10

Pipe support



86.40.50

modular - flexible - versatile

Flange



86.40.41

Pipe clamp



86.40.20

End cap



86.40.25

TUBE SYSTEM

modular - flexible - versatile

Wall support



86.10.04

Ceiling support



86.10.05

Wall support (double)



86.10.01

Wall support heavy duty



86.10.02

Suspension ring - metal



10.48.50.0007

Suspension ring - plastic



10.48.40

Suspension hook - metal



10.48.55 - Ø 34 mm
10.48.58 - Ø 50 mm
10.48.56 - Ø 70 mm

Suspension ring



10.48.52

SWIVEL ARMS

When large or heavy objects need to be moved in and out of a welding booth, overhead rail or tube systems can get in the way. This is especially true when using forklifts or lifting equipment, where free access is essential.

Cepro swivel arms provide the ideal solution. Mounted to a column or wall, they carry welding curtains or strips that can be rotated aside completely, leaving the booth fully open for transport. Once loading or unloading is complete, the arms swing back into position to quickly restore a safe and enclosed work area.

Robust, easy to operate and available in different models, Cepro swivel arms combine flexibility with certified safety, making them the perfect choice wherever freedom of movement and reliable protection must go hand in hand.

Our dedicated product catalogue goes into more detail on all available standard items like welding curtains, strips, blankets, screens etc.

Would you like to receive our product catalogue?

Contact our sales team, we'll be happy to advise you on the best solution for your needs.

wide variety - excellent quality - tailor made possible

Pipe swivel arm - 200cm

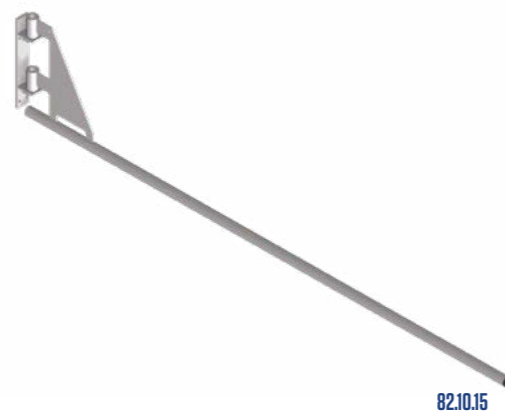

Modular swivel arm - 200cm / 500cm



Swivel arm - 200cm

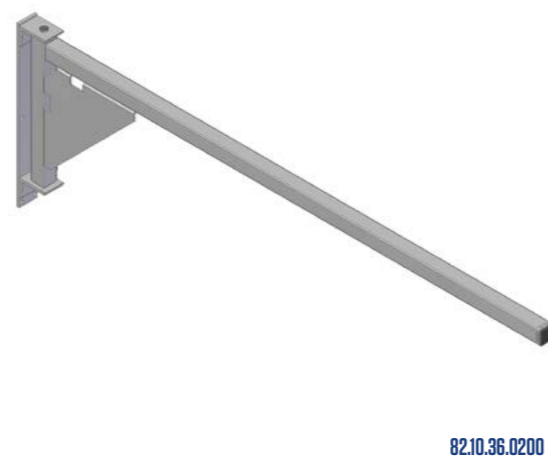

Heavy duty swivel arm

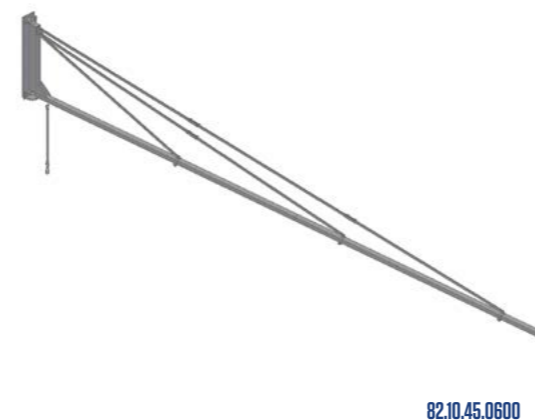

SWIVEL ARMS

wide variety - excellent quality - tailor made possible

Heavy duty swivel arm - hinged

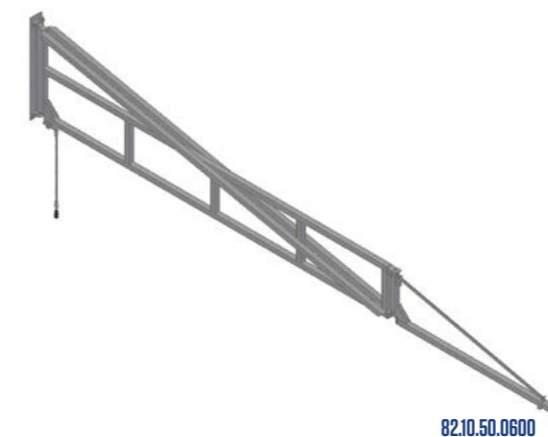

Telescopic swivel arm



Heavy duty swivel arm - 400cm

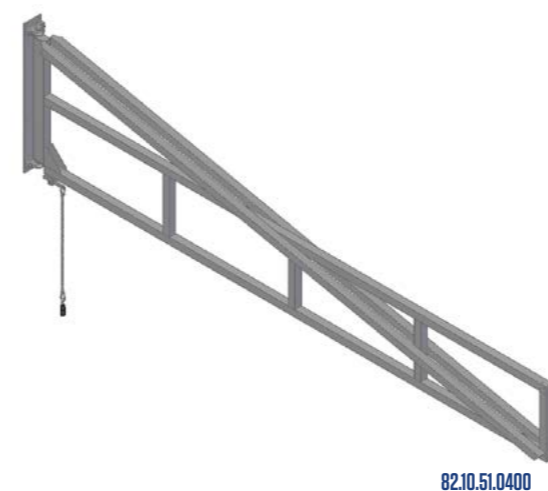

Swivel joint arm



Set for fixing tube under swivel arm



Set for fixing tube under swivel arm



Tag with runner



Fixing set for wire-box



POLES & COLUMNS

Every effective shielding solution needs a strong foundation. Cepro poles and columns provide exactly that. Designed to serve as the backbone of welding booths and protective setups, they are the starting point for building complete configurations with welding strips, curtains and panels.

All Cepro construction parts can be mounted directly to our poles and columns, making it easy to expand or adapt a setup to changing workplace needs. Whether used as fixed supports for a booth or as part of a modular system, they ensure stability, durability and ease of installation.

As the reliable base for countless configurations, Cepro poles and columns make it possible to combine protection, flexibility and efficiency, turning individual components into complete, safe and professional workplaces.

Our dedicated product catalogue goes into more detail on all available standard items like welding curtains, strips, blankets, screens etc.

Would you like to receive our product catalogue?

Contact our sales team, we'll be happy to advise you on the best solution for your needs.

wide variety - excellent quality - tailor made possible

Pole - 50x50x2mm - height 225 / 250 / 300cm



83.10.01.0225 - 225 cm
83.10.01.0250 - 250 cm
83.10.01.0300 - 300 cm

Pole - 100x100x4mm - height 300 / 350 / 400cm

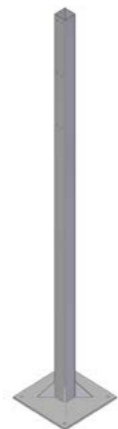

83.20.01.0300 - 300 cm
83.20.01.0350 - 350 cm
83.20.01.0400 - 400 cm

Pole - 80x80x3mm - height 225 / 250 / 300cm

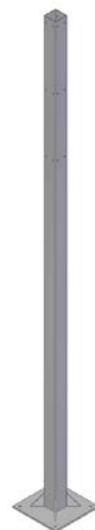

83.10.02.0225 - 225 cm
83.10.02.0250 - 250 cm
83.10.02.0300 - 300 cm
83.10.02.0350 - 350 cm
83.10.02.0400 - 400 cm

Pole - 120x120x5mm - height 300 / 350 / 400cm

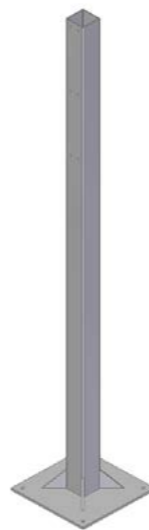

83.20.02.0300 - 300 cm
83.20.02.0350 - 350 cm
83.20.02.0400 - 400 cm

POLES & COLUMNS

wide variety - excellent quality - tailor made possible

Pole - 160x160x6mm - height 300 / 350 / 400cm

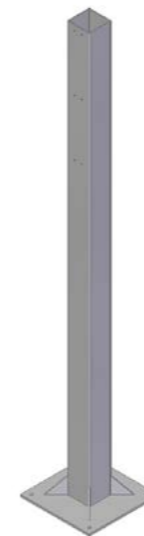

83.20.03.0300 - 300 cm
83.20.03.0350 - 350 cm
83.20.03.0400 - 400 cm



FROM COMPLETE SOLUTIONS TO INDIVIDUAL PRODUCTS

At Cepro, every project is built on a strong foundation: our wide range of standard consumables and components. These products are available directly from stock and form the building blocks of the custom shielding solutions you have seen in this catalogue.

In our product catalogue, you will find the full Cepro range from welding curtains, strips and blankets to mobile welding screens, welding tents etc.. Each item is tested and certified to meet the highest European standards, ensuring the same quality and reliability that we apply in our turnkey projects worldwide.

Whether you need a single consumable, replacement parts, or a complete set-up, our product catalogue provides a clear overview of what Cepro can deliver off-the-shelf.

Curious to learn more?
Request the product catalogue from our sales team or view it online at www.cepro.eu

DID YOU KNOW EVERY CEPRO PROJECT STARTS WITH THE CERTIFIED PRODUCTS YOU'LL FIND IN OUR PRODUCT CATALOGUE?





www.cepro.eu

Cepro International B.V.

Provinciënbaan 16
5121 DL Rijen
Netherland

+31 (0)161 226472
info@Cepro.eu

Cepro Sarl

217, Boulevard de la Liberté
59800 Lille
France

+33 (0)3 20 57 37 66
info@Cepro.fr

Cepro Deutschland GmbH

Germaniastrasse 28
D-44379 Dortmund
Deutschland

+49 (0)3222 – 1092 081
info@Cepro.de

